

USER'S MANUAL



Serial MVP



HAMILTON
THE MEASURE OF EXCELLENCE™



SERIAL MVP OPERATOR'S MANUAL

Part Number 69096 (Rev. C)



Hamilton Company Instrument Warranty

Hamilton Company warrants this equipment (except valves*) to be free of defects in material and workmanship for 12 months from the date of receipt. This warranty is extended to the buyer of record on the original purchase order to Hamilton Company. Hamilton Company or an authorized Hamilton representative agrees to repair or replace, at its option and free of charge to the buyer at a normal place of business or at a Hamilton repair facility, any part or parts that under proper and normal use prove to be defective during the warranty period.** Abuse, unauthorized replacement of parts, modifications, or adjustments made by other than Company or its assigned representatives voids this warranty.

This warranty gives you specific rights. No other warranties, expressed or implied, including implications of warranties of merchantability and fitness for a particular product, are made. Hamilton Company's liability on the sale of all products shall be limited to repair, replacement, or refund of price of any defective product.**

Hamilton Company endeavors to provide prompt and satisfactory service.

*All Hamilton Company valves are warranted to be free of defects in material and workmanship at the time of delivery.

**Hamilton Company reserves the right to refuse to accept the return of any instrument or valve that has been used with radioactive or microbiological substances, or any other material that may be deemed hazardous to employees of Hamilton Company.

GASTIGHT is a registered trademark of Hamilton Company.

Microlab is a registered trademark licensed to Hamilton Company.

SANI-CLOTH is a trademark of Professional Disposables, Inc.

RBS-VIRO is a registered trademark of FLUKA Chemical Corp.

Copyright July 1999, Hamilton Company

Contents

Section 1. Introduction	1-1
1.1 Serial MVP Operational Summary.....	1-2
1.2 Technical Specifications.....	1-3
1.3 Service and Technical Support Procedures	1-4
Section 2. Getting Started	2-1
2.1 Unpacking Your Serial MVP	2-2
2.2 Setting Up the MVP	2-4
2.2.1 Front Panel Components of the MVP	2-4
2.2.1.1 LED/Error Indicator.....	2-4
2.2.1.2 Valve Connector Port	2-6
2.2.1.3 Valve Indexing Pin	2-6
2.2.1.4 Valve Position Indicator	2-6
2.2.1.5 Initialize Membrane Switch	2-7
2.2.1.6 Clockwise and Counterclockwise Membrane Switches.	2-7
2.2.2 Rear Panel Components of the MVP.....	2-7
2.2.2.1 Power Receptacle	2-8
2.2.2.2 DIP Switches S1 and S2	2-9
2.2.2.3 Serial Input/Output Ports	2-9
2.2.3 Power Adapter	2-9
2.2.4 Connecting Valves and Tubing.....	2-10
2.3 Valve Selection.....	2-12
Section 3. Operating the Serial MVP.....	3-1
3.1 Operational Overview of the Serial MVP	3-2
3.2 Manual Operation of the Serial MVP	3-3

3.3	External Control of the Serial MVP.....	3-4
3.3.1	Controller Cable Configuration.....	3-4
3.3.2	Configuration of the Serial MVP for External Control	3-5
3.3.2.1	Determining Valve Position Mode	3-5
3.3.2.2	Loopback Mode	3-7
3.3.2.3	Test Mode.....	3-7
3.3.2.4	Protocol Select.....	3-7
3.3.2.5	Address Selection	3-10
3.3.2.6	Baud Rate Selection.....	3-10
3.4	RS-232 Communication with Manual ASCII Commands	3-12
3.4.1	MVP Protocol 1/RNO+ Syntax Features and Data Format	3-12
3.4.1.1	Data Transfer Format	3-14
3.4.1.2	Command String Components	3-15
3.4.1.3	Auto-addressing	3-15
3.4.1.4	MVP Sample Program.....	3-16
3.4.2	MVP DIN Protocol/BDZ+ Syntax Features and Data Format	3-17
3.4.2.1	Hardwire-addressing.....	3-19
3.4.2.2	Data Transfer Format.....	3-19
3.4.2.3	Termination of Data Transfer	3-20
3.4.2.4	Auto-addressing.....	3-21
3.4.2.5	Broadcast-addressing	3-21
3.5	Instrument Error Status Requests/Responses	3-21
3.6	MVP Demonstration Diskette	3-22
3.7	Initializing the MVP.....	3-22
3.8	Operating the Externally Controlled Serial MVP	3-23
3.9	MVP Errors	3-24
3.9.1	Types of Errors	3-24

3.9.2	Correcting Errors	3-24
3.10	Daily Maintenance	3-25
Section 4.	MVP Protocols	4-1
4.1	Initialization Command	4-2
4.2	Valve Positioning Commands	4-2
4.3	Instrument Control Command	4-3
4.4	Device Control Commands.....	4-3
4.5	Instrument Diagnostic Command	4-4
4.6	Instrument Status Request	4-4
4.7	Instrument Error Request/Response	4-5
4.8	Miscellaneous Device Status Request/Response	4-6
4.9	Instrument Encoder Output Request/Response	4-7
4.10	Instrument Status ASCII Request/Response	4-8
4.11	Configure Valve Command	4-9
4.12	Valve Parameter Request/Response	4-10
4.13	Firmware Version Request/Response	4-11
Section 5.	Maintaining the MVP.....	5-1
5.1	Cleaning and Decontaminating the MVP.....	5-2
5.2	Periodic Maintenance.....	5-3
5.3	Troubleshooting.....	5-4
Section 6.	Ordering Valves, Accessories and Replacement Parts	6-1
6.1	Valve Configurations and Part Numbers	6-2
6.2	Accessories and Replacement Parts.....	6-4
Glossary		GL-1
Index		IN-1

List of Figures

Figure 2-1.	MVP Package Contents.....	2-3
Figure 2-2.	Front Panel of the Hamilton MVP.....	2-5
Figure 2-3.	Rear Panel of the Serial MVP.	2-8
Figure 2-4.	Side View of an HVXM Hamilton Valve.	2-10
Figure 2-5.	Valve Fitting and Flanged Tubing.	2-11
Figure 3-1.	MVP Jumper Settings for Two Operating Protocols	3-9
Figure 6-1.	Communication Cable Configurations	6-5
Figure 6-2.	Power Adapters and Power Cable Configurations.....	6-6

List of Tables

Table 1-1.	Serial MVP Technical Specifications.....	1-3
Table 3-1.	DIP Switch S1	3-3
Table 3-2.	DIP Switch S1	3-6
Table 3-3.	DIP Switch S2.....	3-11
Table 3-4.	Protocol 1/RNO+ Syntax.....	3-13
Table 3-5.	DIN Protocol/BDZ+ Syntax	3-18
Table 3-6.	Initialization of the MVP.....	3-22
Table 4-1.	Initialization Command.....	4-2
Table 4-2.	Valve Positioning Commands	4-2
Table 4-3.	Instrument Control Command.....	4-3

Table 4-4.	Device Control Commands	4-3
Table 4-5.	Instrument Diagnostic Command.....	4-4
Table 4-6.	Instrument Status Request.....	4-4
Table 4-7.	Instrument Error Request/Response.....	4-5
Table 4-8.	Miscellaneous Device Status Request/Response	4-6
Table 4-9.	Instrument Encoder Output Request/Response	4-7
Table 4-10.	Instrument Status ASCII Request/Response	4-8
Table 4-11.	Configure Valve Command.....	4-9
Table 4-12.	Valve Parameter Request/Response.....	4-10
Table 4-13.	Firmware Version Request/Response	4-11
Table 5-1.	MVP Troubleshooting Chart.....	5-4
Table 6-1.	Valve Configurations and Part Numbers for MVP Valves.....	6-2
Table 6-2.	Accessories and Replacement Parts for the Serial MVP.....	6-4

Section 1. Introduction

This operator's manual provides set-up and operational instructions, technical specifications, maintenance and troubleshooting suggestions, ordering information for the serial Modular Valve Positioner (MVP) and replacement Hamilton HVM and HVXM valves.

Two symbols appear throughout this manual to bring special attention to potentially hazardous conditions or suggestions for optimizing the performance of the MVP.



Caution: This symbol warns that a potentially hazardous condition may result for either the MVP or the operator.

→ **Note:** This symbol represents a suggestion for optimizing the performance of the MVP through set-up and operational tips. →

1.1 Serial MVP Operational Summary

The Hamilton MVP controls valves having from two to eight ports with single or multiple fluid paths. Open and close valve ports either manually or through an external controller. Operate the MVP as a stand-alone unit or as a "built-in" instrument for original equipment manufacturers (OEMs).

There are two input/output versions of Hamilton's MVP:

- The serial MVP is compatible with a controller that has an RS-232 serial communications port. Program the serial MVP for six defined valve position modes, and up to 16 daisy-chained, serial MVPs.
- Control the digital MVP with TTL (transistor-transistor logic) or switch closure outputs. Six valve position modes are available, and three command formats are available: discrete, binary and sequential.

This manual describes the use of the serial MVP. The digital MVP, not included in this manual, is described in the *Digital MVP Operator's Manual*.

1.2 Technical Specifications

Technical specifications for the serial MVP are shown in Table 1-1.

Table 1-1. Serial MVP Technical Specifications

Rotational Speed	20 RPM (3 sec. full revolution)
Dimensions	Height: 5.20 in (13.21 cm) Width: 3.52 in (8.94 cm) Depth (without valve): 5.20 in (13.21 cm)
Weight	2.3 lb (1.04 kg) for unit without power adapter
Power Requirements	24VDC @ 500 mA (supplied by power adapter)
Storage Temperature	-40 °F to 160 °F (-40 °C to 70 °C)
Operating Temperature Range	40 °F to 100 °F (5 °C to 40 °C)
Positional Accuracy at Valve Port	+ 7° (valve and MVP unit combined)

1.3 Service and Technical Support Procedures

Contact Hamilton's Technical Support Department TOLL-FREE at +1-800-648-5950 (USA and Canada) if you have questions as you use this manual. Outside the USA and Canada, call +1-775-858-3000. For instrument service call +1-800-527-5269. Hamilton's FAX number is +1-775-856-7259.

Before returning an MVP to Hamilton in Reno for repair, flush out all contaminants. **DO NOT** return tubing or valves. If valve and tubing are contaminated or if they come into contact with biohazard samples, follow safe laboratory practices in selecting and using a cleaning fluid to thoroughly purge and disinfect them prior to storage. Use a cleaning solvent that is compatible with the fluids previously run through the system (deionized water, urea, ethanol, or a bleach and water solutions).

When returning an MVP to Hamilton in Reno, notify Hamilton's Customer Service Department (1-800-648-5950), from 7:00 a.m. to 5:00 p.m. Pacific Time, and request a **Returned Goods Authorization Number (RGA #)**. When calling, please be ready to provide the serial number, product part number, valve type description, and a description of any hazardous material used with the MVP.

Hamilton Company reserves the right to refuse a return shipment of any Hamilton product used with radioactive or microbiological substances or any other material deemed hazardous to its employees.

Returned goods should be delivered to:

Hamilton Company

505 Edison Way

Reno, NV 89502

Section 2. Getting Started

This section provides unpacking information, component descriptions, set up procedures, valve selection information, and preparatory operating instructions for the serial MVP.

2.1 Unpacking Your Serial MVP

Your new MVP has been carefully inspected and packaged, and every precaution has been taken to ensure its safe arrival. Please retain the reusable carton for return or repair of the MVP, if needed.

Inspect the exterior of the shipping container for damage. If damage is evident, contact the carrier immediately and file a report with the appropriate shipping agent.

Check the contents of the package and verify that all parts are included. See Figure 2-1 for a summary of items found in the MVP packing box.

Figure 2-1. MVP Package Contents

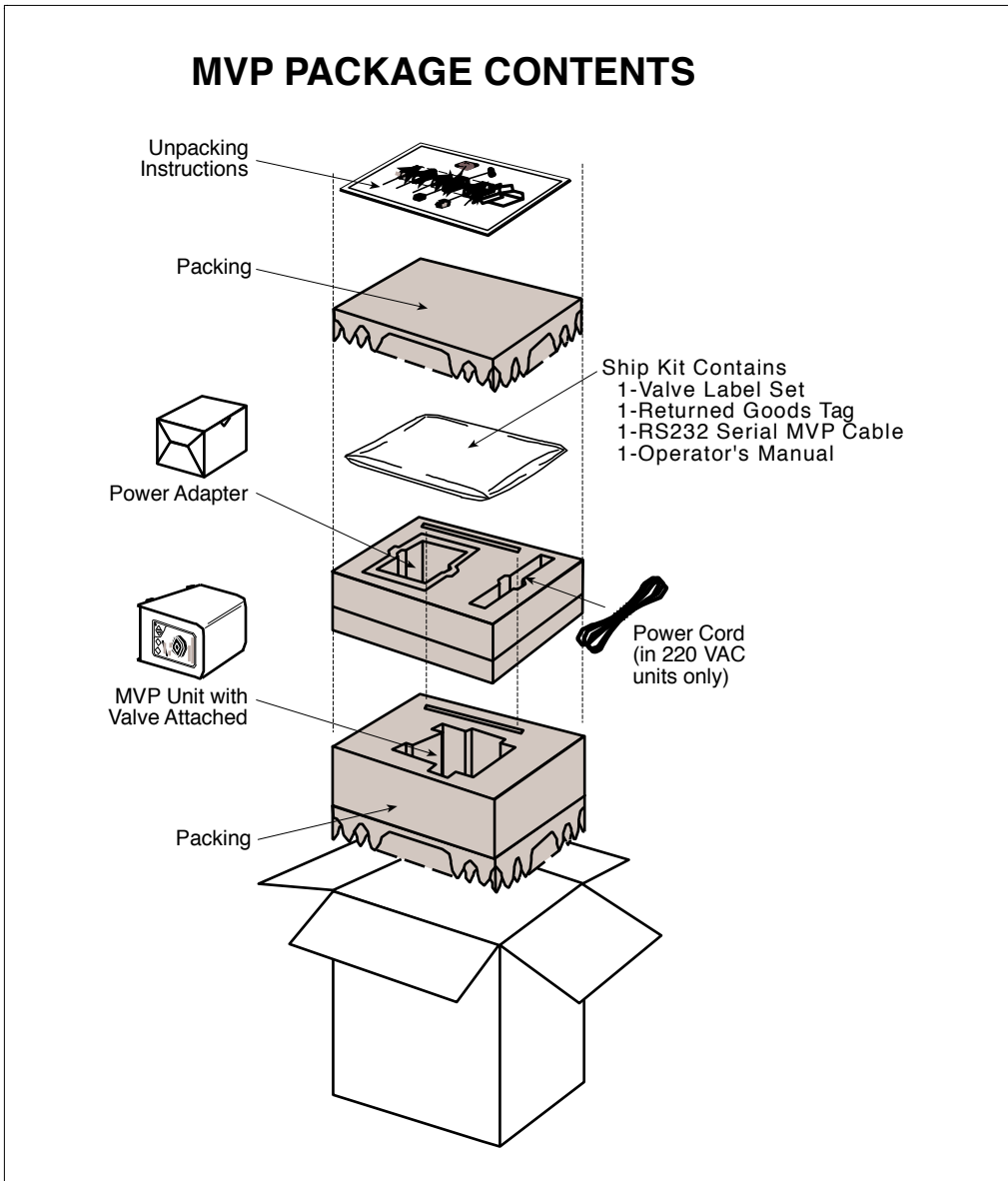

2.2 Setting Up the MVP

The MVP should be set up on a clean, flat and stable surface. There are four suction-cup type feet on the unit to ensure stabilization during operation.

2.2.1 Front Panel Components of the MVP

The MVP has several front panel components which make operation easier. Components of the front panel are described below in detail. Refer to Figure 2-2 for a front panel view of an MVP.

2.2.1.1 LED/Error Indicator

A green light emitting diode (LED) illuminates to indicate the power is on. There is no OFF/ON power switch for the MVP. To turn the unit on or off, connect or disconnect it at the wall outlet or at the adapter cord.

In addition, if an error occurs, the LED flashes and the unit beeps until you correct the problem.

Refer to Section 3.4 for more information on MVP errors.

Figure 2-2. Front Panel of the Hamilton MVP

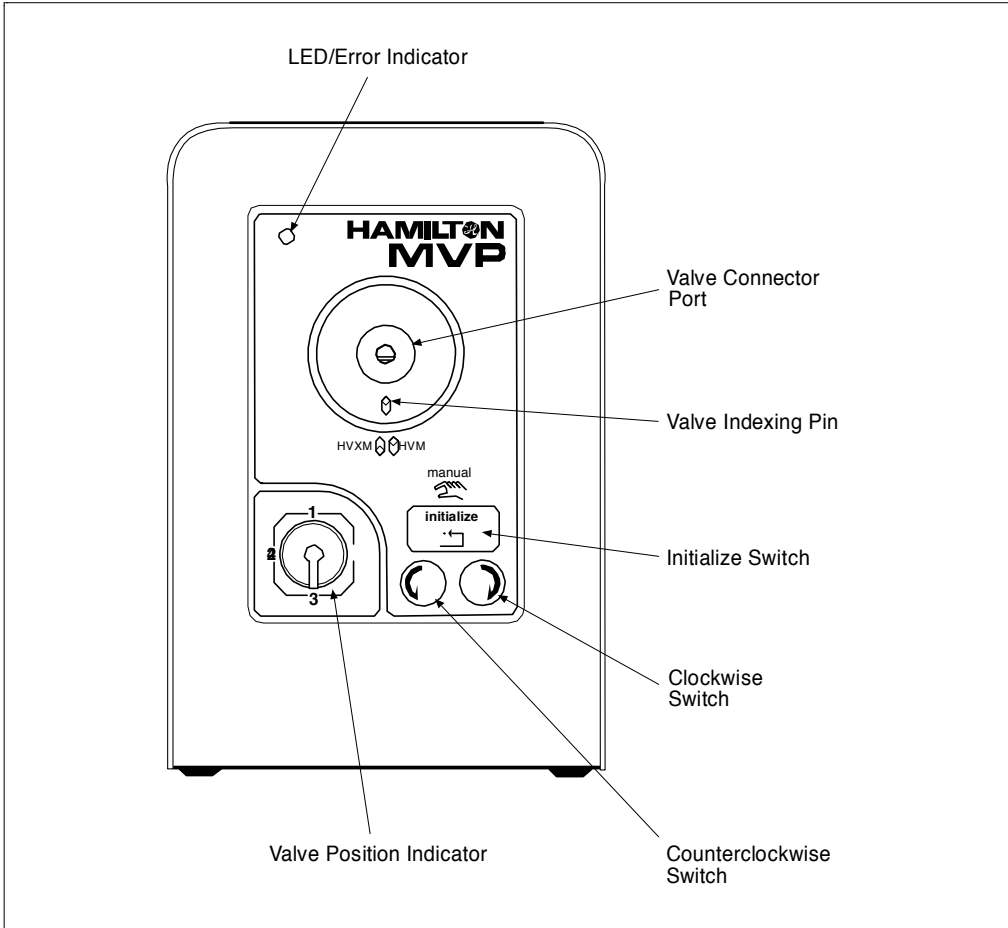

2.2.1.2 Valve Connector Port

The valve connector port houses the MVP's specially designed, removable HVM or HVXM style valves. The port allows quick and easy, tool-free installation and removal of valves.

2.2.1.3 Valve Indexing Pin

The valve indexing pin stabilizes the valve housing, preventing the outside of the valve from rotating while the motor is running. The pin can be shifted to either the up or the down position. The up position is for HVM valves, while the down position is for the larger HVXM valves.

Push the valve indexing pin either up or down.

2.2.1.4 Valve Position Indicator

The appropriate label for the factory-installed valve has been applied to the lower left corner of the MVP front panel. This label represents the external appearance and internal rotating plug of the valve you ordered. It also illustrates the flow path during operation.

A complete set of reusable labels (MVP Valve Porting Label Set, P/N 36778) is included in the ship kit, along with instructions for removing and applying a label onto the MVP following a valve configuration change.

2.2.1.5 Initialize Membrane Switch

The membrane switch labeled "initialize" on the front panel allows the user to initialize or establish the basic conditions for operating the unit.

Initialize the MVP either manually or through an external controller every time you power up the unit , following an MVP error, and after removal and installation of a valve.

2.2.1.6 Clockwise and Counterclockwise Membrane Switches

The membrane switches labeled with clockwise and counterclockwise arrows are manual controls for repositioning the valve. Each time you push one of these switches, the valve will move to the next position in the direction indicated.

If you press these switches before you initialize the MVP, the unit will automatically initialize before it moves to the next valve position.

2.2.2 Rear Panel Components of the MVP

The serial MVP rear panel components include a power receptacle, two DIP switch blocks to configure the MVP, and RS-232 serial input and output ports. The rear panel of the serial MVP appears in Figure 2-3.

Figure 2-3. Rear Panel of the Serial MVP

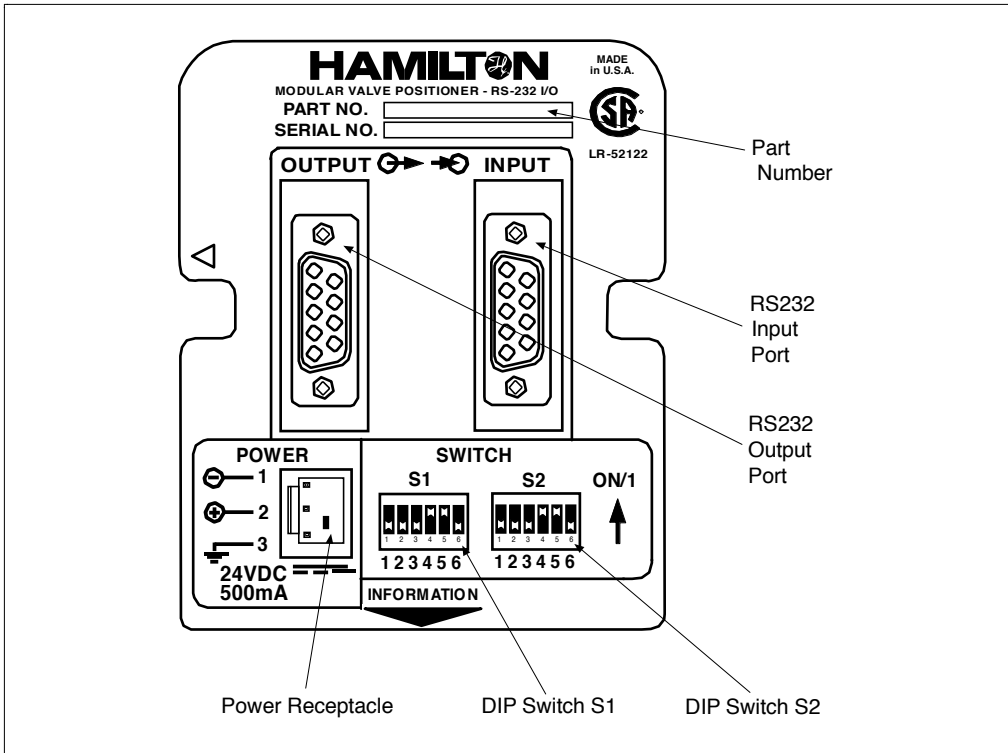

2.2.2.1 Power Receptacle

The power receptacle connects to the MVP power adapter, which in turn is attached to an AC circuit by a three-prong plug.



Caution: Do not attempt to operate the MVP with the ground prong either disconnected or removed.

2.2.2.2 DIP Switches S1 and S2

DIP Switch S1 has six individual switches that allow you to configure the MVP for the number of active valve positions, the required angle between valve positions, loop on or off for daisy-chaining instruments, protocol selection (the MVP is configured at the factory for communication protocol), and a test mode. See Section 3 for more information on setting the DIP switches.

DIP Switch S2 also has six individual positions which you can use to provide a module address for up to 16 daisy-chained instruments and to select the baud rate.

The tables on the bottom of the MVP unit describe switch settings. Refer to Section 3.3.2 for more information.

2.2.2.3 Serial Input/Output Ports

The serial MVP has two DB-9 sockets that serve as input/output ports for communication with a computer or other MVPs.

2.2.3 Power Adapter

The power adapter comes in the MVP package (See Figure 2-1).

Order power adapters for either 120VAC/24VDC, 500 mA (P/N 6500025) or 220VAC/24VDC, 500 mA (P/N 6500026). A power cable (P/N 6541005) is required with the 220VAC/24VDC adapter. Refer to Figure 6-2 for power cable configurations and ordering information.

A universal power supply (90-260VAC/24VDC, 800 mA) (P/N 6500028) is also available and is required for use in Japan (100VAC) and in Australia (240VAC). A standard power cord with an IEC adapter for attaching to the power supply comes with the unit. The power cord has a standard North American three-prong plug on the other end (refer to Figure 6-2). You will need to supply your own power cable or an adapter if the three-prong plug does not work with your power outlet.

2.2.4 Connecting Valves and Tubing



Caution: Hamilton HVM and HVXM valves are specifically designed to operate in Hamilton's MVP. Attempts to install other types of valves, or fittings, tubing, and valves supplied by other manufacturers may cause serious damage to the MVP and may void all warranties.

To install the valve into the MVP, insert the valve stem into the valve connector port on the MVP front panel. Note the slot for the valve indexing pin on the bottom of the valve. Push the valve until it firmly seats against the MVP, with the indexing pin seated into the slot. Place the valve indexing pin in the up position when using HVM valves and in the down position when using the larger HVXM valves.

Figure 2-4. Side View of an HVXM Hamilton Valve

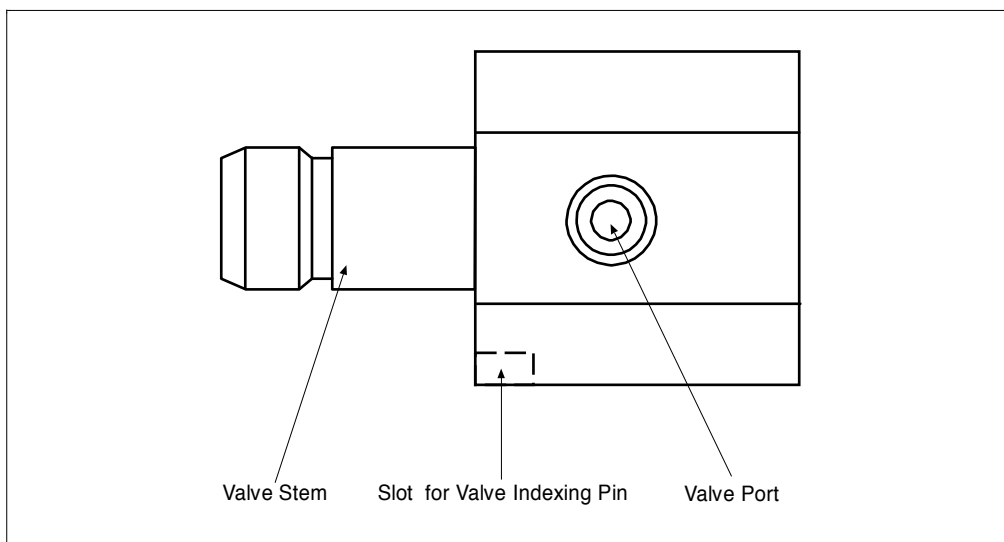

Purchase tubing for the MVP valve in a variety of sizes and materials or without factory-installed tube fittings and washers.

To install the tubing, screw the fitting into the desired valve port. Moisten the fitting with water before inserting it into the valve. Tighten the fitting by hand; do not use tools. Refer to Figure 2-5.

Figure 2-5. Valve Fitting and Flanged Tubing

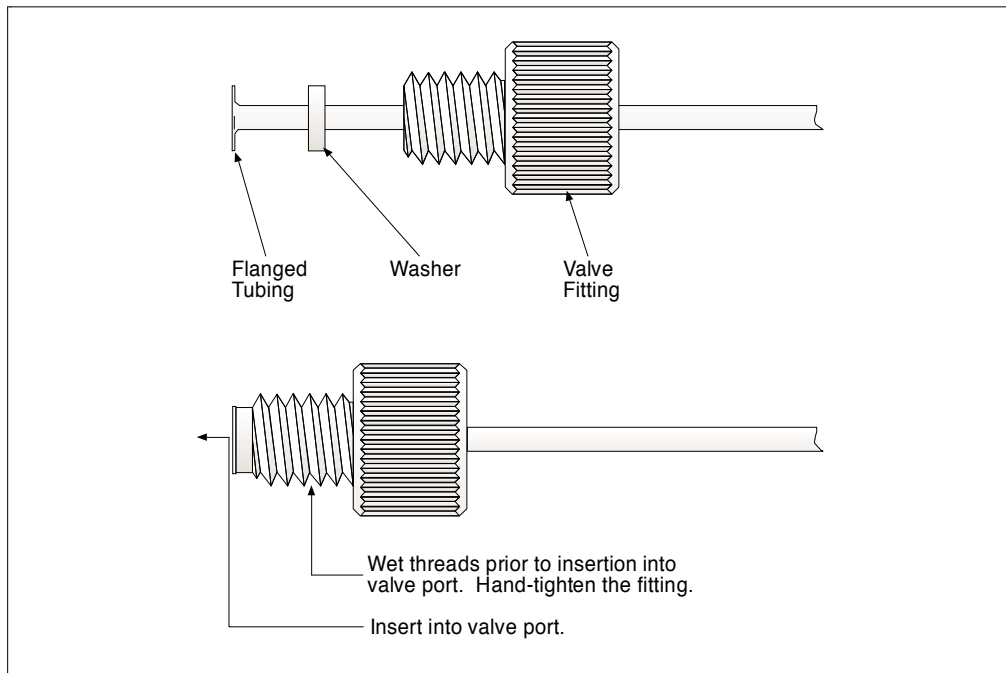

Caution: The tubing fittings and valve can easily be damaged by over tightening, resulting in leaks. Do not use any tools to tighten the fitting. Hand-tighten only.

2.3 Valve Selection

The MVP accepts all Hamilton "M" series HVM and HVXM valves designed specifically for use with the MVP.



Caution: Using valves other than those designated HVM or HVXM for the operation of the MVP may damage the unit and void the warranty.

When selecting a valve, consider the application, liquid viscosity, and flow rate. HVM valves, having internal orifice diameters of 0.059 inches (1.50 mm), will generally work with most systems. With highly viscous fluids or with high flow rates, HVXM valves, having an internal orifice diameter of 0.118 inches (3.00 mm), provide a more adequate option.

There are numerous options for flow in HVM and HVXM valves, differing in the number of ports available on the valve and the angle or direction of flow. There are eight standard valve configurations, six distribution valve configurations, and two valve configurations. Distribution valves have an additional port on the end of the valve, allowing up to eight different fluids to enter one output line. Loop valves are available only as HVXM valves and provide in and out ports for up to four fluids at any one time.

See Section 6 for a complete description of valve flow patterns and ordering information.

Section 3. Operating the Serial MVP

This section provides information on operating the serial MVP. Information is also provided on determining valve position mode, operating protocols, and the types of errors.

3.1 Operational Overview of the Serial MVP

The serial MVP is a microprocessor-controlled unit capable of activating a Hamilton valve with up to eight positions.

Use the manual mode when operating the MVP as a stand-alone unit or when other instruments used in conjunction with the MVP have no external events port or connection. Manually control the unit by pressing membrane switches on the front panel. You can advance (clockwise or counterclockwise) to the next valve position, gaining access to as many as eight valve positions.

When external (computer) control of the MVP is desired, choose from one of two communications protocols: Hamilton Protocol 1/RNO+ Syntax and DIN Protocol/BDZ+ Syntax (default).

3.2 Manual Operation of the Serial MVP

To manually operate the MVP, follow the steps below:

1. Determine the valve position mode from Table 3-1, and set S1 DIP switches 1-3 on the rear of the MVP to correspond with the selected function. OFF is in the down position and ON is in the up position. This information also appears in a table on the bottom of the MVP unit.

These DIP switches were set at the factory to correspond to the valve you ordered. However, if you ordered more than one valve, you may need to reconfigure switches 1-3 after a valve change.

Table 3-1. DIP Switch S1 Configurations for Serial MVP Manual Operation

Function	1	2	3
Valve Position Mode (switches 1-3)			
4 positions at 90°	OFF	OFF	OFF
2 Positions at 90°	ON	OFF	OFF
2 Positions at 180°	OFF	ON	OFF
3 Positions at 90°	ON	ON	OFF
6 Positions at 60°	OFF	OFF	ON
8 Positions at 45°	ON	OFF	ON

2. Ensure that the valve and tubing are in place.



Caution: Operating an MVP without fluid in the valve for extended periods of time reduces the life of the valve. Before initialization, ensure that all tubing is in place and that fluid will enter the valve as soon as possible.

3. Connect the MVP power adapter to the rear of the MVP.
4. Plug the power adapter into a three-prong AC outlet. When the LED illuminates, the MVP is ready for operation.
5. Press the initialize membrane switch. The MVP initializes.

During initialization, the valve rotates clockwise for 1.67 to 2.75 revolutions (at least 601°) and automatically stops at the number 1 position, where it remains until you press another front panel membrane switch.

6. To rotate the valve manually from one port to another, press the appropriate clockwise or counterclockwise switch for each movement of the valve.

3.3 External Control of the Serial MVP

Externally control the serial MVP using two RS232 serial input/output ports on the rear of the MVP unit.

3.3.1 Controller Cable Configuration

Three standard types of cables are available with the serial MVP. Refer to Figure 6-1 for complete cabling diagrams of the available cables.

- The first type of controller cable has a DB9 fitting on both ends for connection to the MVP and a computer.
- The second standard cable configuration has a DB9 cable connector on one end and a DB25 connector on the other for a computer.
- The third type of standard cable connects the output port of the MVP to the input of the next in daisy-chained MVPs.

3.3.2 Configuration of the Serial MVP for External Control

Configure the serial MVP for external control with DIP Switches S1 and S2 on the rear of the MVP unit. Refer to Tables 3-2 and 3-3 for DIP switches S1 and S2 settings. An X in any column indicates the switch does not control that function.

3.3.2.1 Determining Valve Position Mode

Valve position mode is determined by the function desired and the valve selected. Table 3-2 shows six options available for valve position mode. Two open channels are available for OEM or specially programmed functions.

Set DIP Switch S1 switches 1-3 to prepare the MVP for valve position mode based on the valve chosen.

This information also appears in a table on the bottom of the MVP unit.

Table 3-2. DIP Switch S1 Configurations for External MVP Control

Function	1	2	3	4	5	6
Valve Position Mode (switches 1-3)						
4 Positions at 90°	OFF	OFF	OFF	X	X	X
2 Positions at 90°	ON	OFF	OFF	X	X	X
2 Positions at 180°	OFF	ON	OFF	X	X	X
3 Positions at 90°	ON	ON	OFF	X	X	X
6 Positions at 60°	OFF	OFF	ON	X	X	X
8 Positions at 45°	ON	OFF	ON	X	X	X
Open 1	OFF	ON	ON	X	X	X
Open 2	ON	ON	ON	X	X	X
Loopback Mode (switch 4)						
Loop Off	X	X	X	OFF	X	X
Loop On*	X	X	X	ON	X	X
Test Mode (switch 5)						
Test Off	X	X	X	X	OFF	X
Test On	X	X	X	X	ON	X
Protocol Select (switch 6)						
Protocol DIN	X	X	X	X	X	OFF
Protocol 1	X	X	X	X	X	ON
* Switch S4 must be in the OFF position at all times when using the DIN Protocol/BDZ+ Syntax. It will be in the ON position only for the last unit in a daisy-chain and when using Protocol 1/RNO+ Syntax.						

3.3.2.2 Loopback Mode

Configure the MVP for daisy-chaining by placing switch S1-4 in the ON position for the last unit in the chain. If only one instrument is used, switch S1-4 must be in the ON position. When several units are daisy-chained, only the last unit in the chain should have the S1-4 switch in the ON position. All other units should have the switch in the OFF position.

Note that if you are using the DIN Protocol/BDZ+ Syntax, all daisy-chained units, including the last one in the chain, must have switch S1-4 in the OFF position.

3.3.2.3 Test Mode

A self-test mode is activated when the MVP is configured for Test Mode (switch S1-5 in the ON position). Test mode moves the valve through all positions defined by the Position Mode for six revolutions. The system then performs quasi-random positioning and directional movements. The test mode continues indefinitely until the power is disconnected or the configuration in DIP Switch S1 is changed.

The test mode is accessible only with manual control of the MVP, and allows the user to determine if the Position Mode is correctly programmed in DIP Switch S1.

3.3.2.4 Protocol Select

Two primary protocols are available: DIN Protocol/BDZ+ Syntax and Hamilton Protocol 1/RNO+ Syntax. The MVP is configured for you at the factory. However, if you change instrumentation or operating protocol for whatever reason, you will need to reconfigure your instrument. To reconfigure your instrument, you will need to remove the back cover.



Caution: If your instrument is still under warranty, arrange to have the unit sent to Hamilton for reconfiguration of inside components. Opening the unit may void your warranty.

If your unit is out of warranty and you wish to reconfigure inside components, remove the back cover of the MVP by removing the two Phillips-head screws holding the back cover to the unit.

Locate pin blocks JP1 and JP2 on the interface board. JP1 is located on the right side of the interface board, and JP2 is located on the left side of the board. Three jumpers or shunts (P/N 6539086) are required for the Hamilton Protocol 1/RNO+ Syntax on JP1 to connect pins 1 and 2, pins 4 and 5, and pins 7 and 8. Three jumper pins are also required on JP2 to connect pins 1 and 8, pins 2 and 7, and pins 3 and 6. See Figure 3-1.

When using DIN Protocol/BDZ+ Syntax, two jumper pins are required for JP1 to connect pins 2 and 3 and pins 6 and 7. Two pins are also required for JP2 to connect pins 1 and 2 and pins 6 and 7. See Figure 3-1.

When you change from one operating protocol to the other, you will need to reposition the jumpers. Note that the Protocol 1/RNO+ Syntax requires six jumpers while DIN Protocol/BDZ+ Syntax requires four. You will need to purchase two additional jumpers (P/N 6539086) to go from DIN Protocol/BDZ+ Syntax to Protocol 1/RNO+ Syntax.

Change the positions of the jumpers by simply pulling them out of their present location and pushing them into their new position. Use a small pair of needle-nose pliers if necessary.

Call Hamilton Company's Technical Support Department if you need assistance: in USA and Canada call +1-800-648-5950; all others call +1-775-858-3000.

Figure 3-1. MVP Jumper Settings for Two Operating Protocols

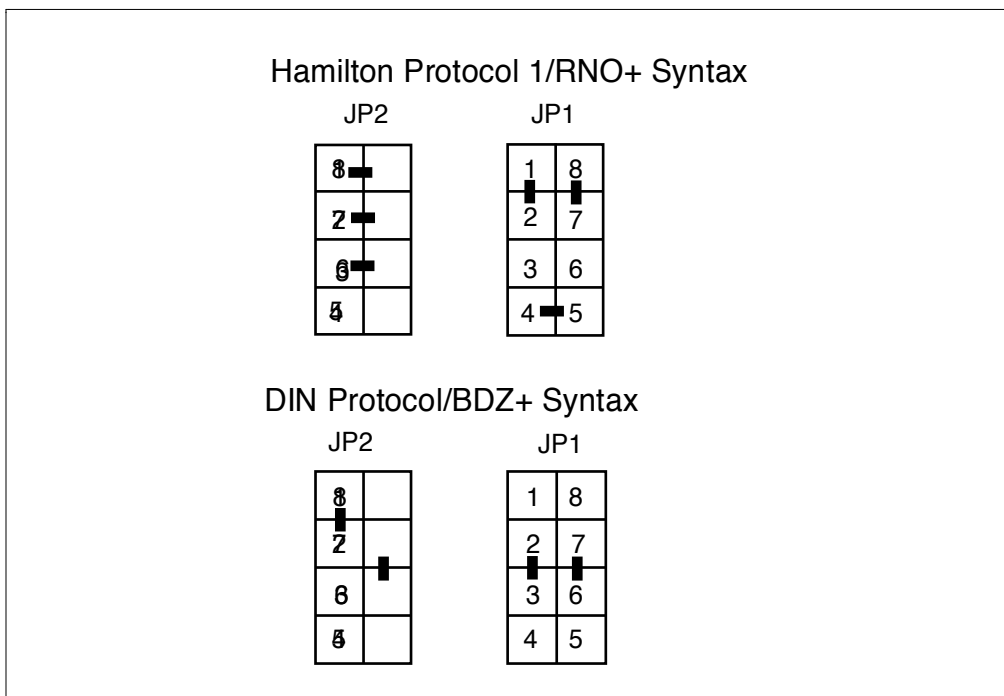

3.3.2.5 Address Selection

Daisy-chain up to 16 MVPs to operate simultaneously. The computer auto-addresses any daisy-chained units unless you choose to hardwire-address the units. The hardwire-addressing option is only available with DIN Protocol/BDZ+ Syntax and you must assign an address or location for each unit along the daisy chain. Refer to Table 3-3 to assign the address for each unit. Set DIP switch S-2, switches 1-4 for hardwire addressing. This information also appears in a table on the bottom of the MVP unit.

Note during auto-addressing that DIP switch S2 switches 1-4 are over-ridden by the computer and you can ignore the settings of these switches.

3.3.2.6 Baud Rate Selection

Baud rate is the rate at which information can be transmitted between computer devices. Four baud rates are commonly used: 9600 (default), 4800, 2400, or 1200 bits per second. The baud rate is usually set on the controlling instrument, and does not change. Check your computer manual to determine the baud rate. Set the baud rate of the MVP using DIP switch S2, switches 5 and 6. Refer to Table 3-3 or the table on the bottom of the MVP unit for correct settings.

Table 3-3. DIP Switch S2 Configurations

Function	1	2	3	4	5	6
Address (switches 1-4)*						
1	OFF	OFF	OFF	OFF	X	X
2	ON	OFF	OFF	OFF	X	X
3	OFF	ON	OFF	OFF	X	X
4	ON	ON	OFF	OFF	X	X
5	OFF	OFF	ON	OFF	X	X
6	ON	OFF	ON	OFF	X	X
7	OFF	ON	ON	OFF	X	X
8	ON	ON	ON	OFF	X	X
9	OFF	OFF	OFF	ON	X	X
10	ON	OFF	OFF	ON	X	X
11	OFF	ON	OFF	ON	X	X
12	ON	ON	OFF	ON	X	X
13	OFF	OFF	ON	ON	X	X
14	ON	OFF	ON	ON	X	X
15	OFF	ON	ON	ON	X	X
16	ON	ON	ON	ON	X	X
Baud Rate Select (switches 5 and 6)						
9600	X	X	X	X	OFF	OFF
4800	X	X	X	X	ON	OFF
2400	X	X	X	X	OFF	ON
1200	X	X	X	X	ON	ON
* DIP Switch S2 switches 1-4 are used only with hardwire-addressing with the DIN Protocol/BDZ+ Syntax. The switches are overridden in auto-addressing.						

3.4 RS-232 Communication with Manual ASCII Commands

Two communication protocols are available with Hamilton's MVP: DIN Protocol/BDZ+ Syntax, and the standard Hamilton Protocol 1/RNO+ Syntax. See Section 4 for more detailed programming information.

3.4.1 MVP Protocol 1/RNO+ Syntax Features and Data Format

- 📁 **NOTE: A DOS demonstration diskette featuring Protocol 1/RNO+ Syntax is available free of charge for on-site MVP evaluations. Contact Hamilton's Customer Service Department to obtain the diskette.** 📁

The Hamilton Protocol 1/RNO+ Syntax is used to communicate with instruments (diluters, syringe modules, and valve positioners) designed and manufactured by Hamilton Company.

- Multiple instruments may be linked in a daisy-chain configuration. All messages transmitted from the Master Controller receive a message echo.
- With the exception of the auto-address command, the Master Controller receives all messages transmitted from the instruments.
- The Master Controller will auto-address up to 16 units (see Section 3.4.1.3 for auto-addressing).
- The communication hardware format required is compatible with the industry standard RS-232 interface, using only RXD, TXD, and GND.

Data Format

Interface: RS-232 (using only RXD, TXD, and GND)

Baud: 9600 (default), 4800, 2400, 1200

Parity: Odd

Data Bits: 7

Stop Bits: 1

Start Bits: 1

Protocol 1/RNO+ Syntax uses three basic control characters (Table 3-4).

Table 3-4. Protocol 1/RNO+ Syntax

Notation	Name	ASCII Code	Description
<CR>	Carriage Return	13	A control character that ends the text of an instruction
<ACK>	Acknowledge	06	A control character transmitted by the slave instrument indicating an affirmative response to the controlling device
<NAK>	Negative Acknowledge	21	A control character transmitted by the slave instrument indicating a non-affirmative response to the controlling device

3.4.1.1 Data Transfer Format

To enter and send a command string use the following format:

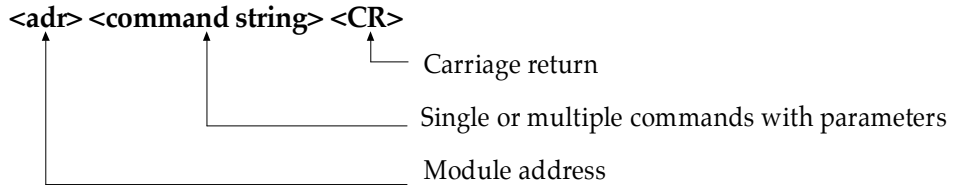

Each character transmitted to the MVP is hardware-echoed as it is sent:
<adr> <command string> <CR>

The MVP responds as follows:

<ACK> <CR>

The diagram shows the response format **<ACK> <CR>**. An arrow points from the label "Acknowledge (if no parity or syntax errors)" to the "<ACK>" component.

or

<ACK> <query response> <CR> (if valid query command sent)

or

<NAK> <CR>

The diagram shows the response format **<NAK> <CR>**. An arrow points from the label "Negative Acknowledge (everything else)" to the "<NAK>" component.

3.4.1.2 Command String Components

A command string contains a single valve command for the serial MVP

It is possible to enter commands into the MVP buffer without having to execute them. Execution of commands occurs in the order received when you enter the **R** (execute) command at the end of the command string.

- ⓘ **NOTE: If you enter a new command before a pending command executes, the pending (or original) command will be lost.** ⓘ

3.4.1.3 Auto-addressing

- ⓘ **NOTE: Hardwire-addressing is not supported by Protocol 1/RNO+ Syntax. Auto-addressing will override hardwire-addressing.** ⓘ

To auto-address MVPs, the controlling device must transmit the following:

1a <CR>

The first MVP will store the address 'a' in memory and transmit the same auto-address command to the next MVP on the daisy chain with an incremented address (i.e., **1 <ADR +1> <CR>**). Gradually, the controlling device will receive an auto-address command with an address equal to the last MVP on the daisy-chain plus one (i.e., **1 <last ADR + 1> <CR>**). There is no echo during the auto-address command sequence.

The auto-address command must be the first sequence of characters transmitted to the MVPs. Until the auto-address command is sent and addresses are assigned to the MVPs, the MVPs will neither respond nor execute any controller commands.

3.4.1.4 MVP Sample Program

The following examples demonstrate a sample program for the MVP .

Valve Command

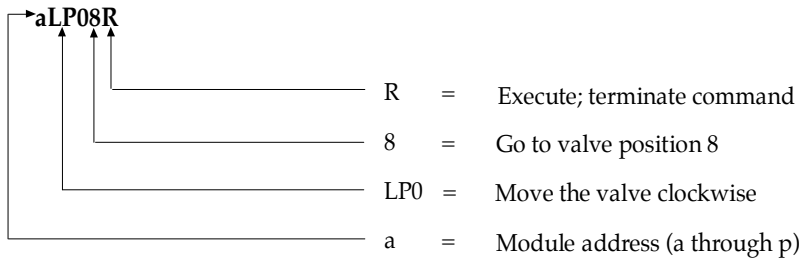

Valve Command

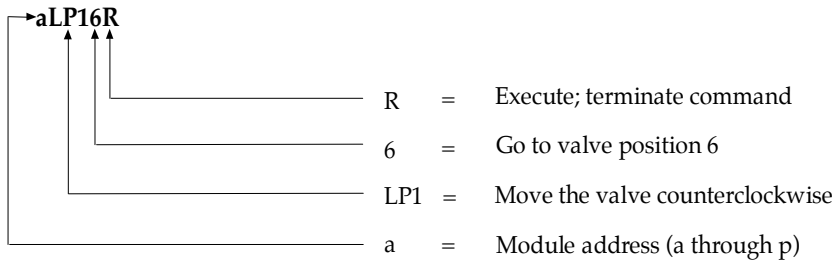

Valve Command

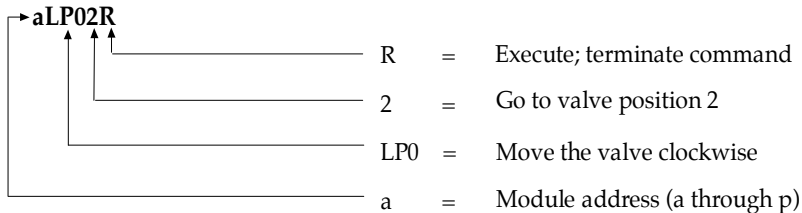

3.4.2 MVP DIN Protocol/BDZ+ Syntax Features and Data Format

The DIN Protocol/BDZ+ Syntax for the MVP is based primarily on the DIN 66019 standard. Please note that this protocol will not work with the demonstration diskette that is currently available. The following specifications apply:

- Instruments are linked in a daisy-chained configuration. The Master Controller transmits data to one instrument at a time, with the slave instrument responding only to the Master Controller.
- Unlike Protocol 1, two ASCII characters are assigned for instrument address (00-16).
- Both auto- and hardwire-addressing are available.
- The required communication hardware format is compatible with the industry standard RS-232, using only RXD, TXD, and GND.

Data Format

Interface:	RS-232 (using only RXD, TXD, and GND)
Baud:	9600 (default), 4800, 2400, 1200
Parity:	Even
Data Bits:	7
Stop Bits:	2

The DIN Protocol/BDZ+ Syntax uses six basic control characters as taken from ISO 646. (Refer to Table 3-5.)

Table 3-5. DIN Protocol/BDZ+ Syntax

Notation	Name	ASCII Code	Description
<STX>	Start of Text	02	A control character that starts the text of an instruction (i.e., the head of the message)
<ETX>	End of Text	03	A control character that ends the text of an instruction (i.e., the tail of the message)
<EOT>	End of Transmission	04	A control character that ends the data transfer session to the device
<ENQ>	Inquiry	05	A control character that starts a data transfer session to the device
<ACK>	Acknowledge	06	A control character transmitted by a receiving device indicating an affirmative response to the transmitting device
<NAK>	Negative Acknowledge	21	A control character transmitted by a receiving device indicating a non-affirmative response to the transmitting device

3.4.2.1 Hardwire-addressing

A unique address (1 through 16) may be set using DIP Switches S2, switches 1-4, for each MVP on a daisy-chain (refer to Table 3-3). Note that hardwire-addressing is available only with DIN Protocol/BDZ+ Syntax.

Before any data transfer can take place between the controlling device and the MVP(s), the controlling device must first confirm the address for each MVP. To accomplish this, transmit the following:

<ADR>
<ENQ>

If connected, a MVP with a matching address will respond with the following:

<ADR>
<ACK>

After this exchange sequence, you may transfer data.

3.4.2.2 Data Transfer Format

Control characters <STX> and <ETX>, and the Block Control Characters (**BCC**) which terminate the command string, encapsulate a command.

<STX> <command string> <ETX> **BCC**

If the slave MVP receives a command string without any transmission errors, it will respond with an '**acknowledge**' response (i.e., <ACK>). In all other cases, the slave MVP responds with a '**negative acknowledge**' response (i.e., <NAK>), including all illegal transmissions resulting from parity errors or an improper **BCC**.

If the controlling device transmits a unit status query (i.e., status bit or firmware request), the slave MVP will respond with an '**acknowledge**' response followed by the given status.

The **BCC** is generated by inverting the result of the 'Exclusive OR' (**XOR**) operation of all the ASCII values in the command string one at a time and **XOR** with the **<ETX>** value. The **BCC**, calculated in 7 bits, follows:

BCC = ASCII value of command 1

BCC = BCC XOR ASCII value of command 2

BCC = BCC XOR ASCII value of command 3

BCC = BCC XOR ASCII value of command 4

BCC = BCC XOR ASCII value of the last command n

BCC = BCC XOR **<ETX>** ASCII value

BCC = Inverse BCC

3.4.2.3 Termination of Data Transfer

The transmission of **<EOT>** by the controlling device will end the data transfer between the addressed MVP and the controlling device. The **<EOT>** command must be sent to an addressed MVP before establishing data transfer with another MVP. **<EOT>** is not an 'acknowledge' response.

3.4.2.4 Auto-addressing

Auto-addressing is also supported by the DIN Protocol/BDZ+ Syntax. The controlling device must transmit the following to initiate auto-addressing:

00 <ENQ>	=	addresses all MVPs
<STX> Y <ETX> BCC	=	clear hardware addresses
<EOT>	=	accepts auto addresses
!01 <EOT>	=	address 01 is sent to the first MVP

Each MVP stores the assigned address before transmitting an incremented address (i.e., !<ADR + 1> <EOT>) to the next instrument on the daisy chain.

3.4.2.5 Broadcast-addressing

Address all MVPs on the daisy chain when transmitting address '00' by way of the controlling device (i.e., 00 <ENQ>). The MVPs execute any command string transmitted. Broadcast addressing does not allow unit queries, or <ACK> or <NAK> replies. The common addresses remain active until receiving an <EOT>.

3.5 Instrument Error Status Requests/Responses

Since the MVP functions as a slave device, errors and statuses need to be queried (refer to Section 6, "MVP Protocols," for all status request commands).

3.6 MVP Demonstration Diskette

A customer-oriented demonstration diskette featuring Protocol 1/RNO+ Syntax is available upon request. The software runs on any IBM-compatible computer (with DOS) and will guide you through the basic programming.

To use the 3 1/2" diskette, simply insert the floppy disk into the disk drive. At the prompt, type MVPDEMO, and the menu of operations will appear.

3.7 Initializing the MVP

Initialize the MVP to establish a "home" position before operating. When fully initialized, under the default mode, the MVP 's valve locates and stops at position 1.

Upon starting the instrument and before the MVP accepts any movement commands, initialize the valve by sending an initialization command.

Ⓢ **NOTE: Address the MVP before attempting to send any commands.** Ⓢ

An example of an initialization command appears in Table 3-6.

Table 3-6. Initialization of the MVP

Computer Command	Example	Explanation
<address>LX	aLXR	Initialize the valve on module "a."

3.8 Operating the Externally Controlled Serial MVP

To operate the externally controlled serially MVP, follow the steps below:

1. Determine the valve position mode, loopback mode, and the communication protocol from Table 3-2. Determine the module address and baud rate from Table 3-3. Set switches 1-6 in DIP Switches S1 and S2 on the rear of the MVP to correspond with the selected functions. OFF is in the down position and ON is in the up position.

These DIP switches were set at the factory for the valve ordered and any other specifications given. However, if more than one valve was ordered or the controller specifications were unknown, the switches may need to be reconfigured.

2. Ensure that the valve and tubing are in place.



Caution: Operating an MVP without fluid in the valve for extended periods of time reduces the life of the valve. Before initialization, ensure that all tubing is in place and that fluid will enter the valve as soon as possible.

3. Connect the MVP power adapter to the rear of the MVP (See Figure 2-3).
4. Plug the power adapter into a three-prong AC outlet. When the LED illuminates, the MVP is ready for operation.

3.9 MVP Errors

MVP errors are of two types: command format errors or position errors. An MVP error is indicated by a flashing front panel LED and a beep.

3.9.1 Types of Errors

- **Command Format Errors** occur when the unit receives one of the following invalid commands:
 1. The MVP receives an invalid valve position command (for example, issuing a position #4 command when DIP Switch S1 is configured for a 2-way valve).
 2. The Position Mode switch is on the undefined Open 1 or Open 2 setting (invalid position mode).
 3. Switch block settings are improperly set.
When the MVP is in test mode or when the MVP is busy, it will ignore input commands.
- **Position Errors** are caused by a movement or encoder error (a stalled motor or faulty encoder signal).

3.9.2 Correcting Errors

Most serial MVP command format errors are corrected by resetting the DIP Switch S1 switches to their correct settings. Remember to disconnect the power cable before resetting the switches. Reset the switches, power up, and initialize the unit.

Correct position errors by reinitializing the unit.

3.10 Daily Maintenance

At the end of each work day, purge the instrument and leave the tubing filled with distilled water. This is particularly important if you are using buffers or other salt solutions which could accumulate or crystallize in the valve. Leave the tube ends in a beaker of distilled water.

For long term storage, purge the instrument. Cycle air through it until the system is dry. Then remove tubes. Cover the instrument to protect it from damage.

Section 4. MVP Protocols

This section provides information on the two MVP protocols supported by Hamilton Company: Protocol 1/RNO+ Syntax and DIN Protocol/BDZ+ Syntax

4.1 Initialization Command

Table 4-1. Initialization Command

Protocol 1/RNO+		DIN Protocol/BDZ+		
LX	---	I1	---	<ol style="list-style-type: none"> 1. Rotate valve a minimum of 360 degrees 2. Stop valve at the input position

4.2 Valve Positioning Commands

Table 4-2. Valve Positioning Commands

Protocol 1/RNO+		DIN Protocol/BDZ+		
L	Pdpp Aaaa	V	vd waaa npp	Valve Positioning d = 0, CW d = 1, CCW pp = 1-8, valve positions aaa = 0-345 degrees, absolute angles from 0 degrees @ 15 degree increments

NOTE: Each command string must include three elements: MVP address <ADR>, command string <command string>, and carriage return <CR> (refer to Section 3).

4.3 Instrument Control Command

Table 4-3. Instrument Control Command

Protocol 1/RNO+		DIN Protocol/BDZ+		
!	---	R	---	Reset Instrument Default Values Must re-address and re-initialize instrument
---	---	Y	---	Clear Hardware-addressing Configure communication for auto-addressing

4.4 Device Control Commands

Table 4-4. Device Control Commands

Protocol 1/RNO+		DIN Protocol/BDZ+		
K	---	Uk	---	Halt all device commands in progress
\$	---	Ur	---	Resume all device commands
V	---	Uc	---	Clear all pending device commands

4.5 Instrument Diagnostic Command

Table 4-5. Instrument Diagnostic Command

Protocol 1/RNO+		DIN Protocol/BDZ+		
ET	---	Ut	---	Put instrument in diagnostic mode Diagnostic is halted by the 'Reset' command

4.6 Instrument Status Request

Table 4-6. Instrument Status Request

Protocol 1/RNO+		DIN Protocol/BDZ+		
E1	B1	Q	QB1	Instrument Status Request Byte B1 Bit 0 = Instrument received command, but not executed Bit 1 = (N/A) Bit 2 = Valve drive is busy Bit 3 = Syntax error Bit 4 = Instrument Error (valve error) Bit 5 = Always 0 Bit 6 = Always 1 Bit 7 = Parity (0 = false; 1 = true)

4.7 Instrument Error Request/Response

Table 4-7. Instrument Error Request/Response

Protocol 1/RNO+		DIN Protocol/BDZ+		
* E2	B1 B2 B3 B4	E	E B1 B2	Instrument Error Request/Response
Query E2 to clear errors				Bytes B1-B2 Bit 0 = Valve not initialized Bit 1 = Valve initialization error Bit 2 = Valve overload error Bit 3 = Always 0 Bit 4 = Always 0 Bit 5 = Always 0 Bit 6 = Always 1 Bit 7 = Parity Byte B3: Always 50h Byte B4: Always 50h (0 = false; 1 = true)

NOTE: Each command string must include three elements: MVP address <ADR>, command string <command string>, and carriage return <CR> (refer to Section 3).

4.8 Miscellaneous Device Status Request/Response

Table 4-8. Miscellaneous Device Status Request/Response

Protocol 1/RNO+		DIN Protocol/BDZ+		
E3	B1	Xs	Xs B1	Miscellaneous Device Status Request/Response Byte B1 Bit 0 = Timer Busy Bit 1 = Diagnostic Mode Busy Bit 2 = (N/A) Bit 3 = (N/A) Bit 4 = Over Temperature Error Bit 5 = Always 0 Bit 6 = Always 1 Bit 7 = Parity (0 = false; 1 = true)

NOTE: Each command string must include three elements: MVP address <ADR>, command string <command string>, and carriage return <CR> (refer to Section 3).

4.9 Instrument Encoder Output Request/Response

Table 4-9 Instrument Encoder Output Request/Response

Protocol 1/RNO+		DIN Protocol/BDZ+		
E4	B1 B2	---	---	Instrument Encoder Output Request/Response Byte B1 Bit 0 = (N/A) Bit 1 = (N/A) Bit 2 = Valve Encoder Output Bit 3 = Always 0 Bit 4 = Always 0 Bit 5 = Always 0 Bit 6 = Always 1 Bit 7 = Parity Byte B2: Always 40h

ⓘ **NOTE:** Each command string must include three elements: MVP address <ADR>, command string <command string>, and carriage return <CR> (refer to Section 3). ⓘ

4.10 Instrument Status ASCII Request/Response

Table 4-10. Instrument Status ASCII Request/Response

Protocol 1/RNO+		DIN Protocol/BDZ+		
Ⓢ		---	---	Movement Finished ? Request/Response x = N The valve has received a command, but not executed x = Y Finished x = * Busy
Ⓢ				Valve Overload ? Request/Response x = Y Valve overload x = N No error x = * Busy

Ⓢ **NOTE:** Each command string must include three elements: MVP address <ADR>, command string <command string>, and carriage return <CR> (refer to Section 3).Ⓢ

4.11 Configure Valve Command

Table 4-11. Configure Valve Command

Protocol 1/RNO+		DIN Protocol/BDZ+		
LS	Tx	S	vx	Set Valve Type x = 2 8 ports @ 45 degrees apart x = 3 6 ports @ 60 degrees apart x = 4 3 ports @ 90 degrees apart x = 5 2 ports @ 180 degrees apart x = 6 2 ports @ 90 degrees apart x = 7 4 ports @ 90 degrees apart (default)
	Fy		zy	Set Valve Motor Speed y = 0 30 Hz y = 1 40 Hz y = 2 50 Hz y = 3 60 Hz y = 4 *70 Hz y = 5 *80 Hz y = 6 *90 Hz y = 7 *100 Hz y = 8 *110 Hz y = 9 *120 Hz

* If you plan to operate at >60 Hz, please contact Hamilton Company prior to use.

4.12 Valve Parameter Request/Response

Table 4-12. Valve Parameter Request/Response

Protocol 1/RNO+		DIN Protocol/BDZ+		
LQP	xx	Ap	Apxx	Valve Position Request/Response
LQA			Asxxx	xx = 1-8
LQT	xxx	Aa	Avx	Valve Angle Request/Response
	x	Av		xxx = 0-359 degrees
LQF			Azy	Valve Type Request/Response
	y	Az		x = 2 8 ports x = 3 6 ports x = 4 3 ports x = 5 2 ports @ 180 degrees apart x = 6 2 ports @ 90 degrees apart x = 7 4 ports
				Valve Speed Request/Response
				y = 0 30 Hz
				y = 1 40 Hz
				y = 2 50 Hz *
				y = 3 60 Hz
				y = 4 70 Hz
				y = 5 80 Hz
				y = 6 90 Hz
				y = 7 100 Hz
				y = 8 110 Hz
				y = 9 120 Hz

*For y = 2-9, valve speeds apply only to Protocol 1/RNO+ Syntax.

4.13 Firmware Version Request/Response

Table 4-13. Firmware Version Request/Response

Protocol 1/RNO+		DIN Protocol/BDZ+		
U	OMii.jj.kk	F	FOMii.jj.kk	Instrument Firmware Version Request/Response ii = 0-99 jj = 0-99 kk = 0-99

- **NOTE:** Each command string must include three elements: MVP address <ADR>, command string <command string>, and carriage return <CR> (refer to Section 3).•

Section 5. Maintaining the MVP

This section explains routine maintenance procedures that help ensure proper operation of the MVP.

There are no user-serviceable parts inside the MVP.

5.1 Cleaning and Decontaminating the MVP

- Always unplug the MVP when performing any maintenance or cleaning.
- To reduce wear on the MVP valve, do not operate the MVP without fluid in the valve.
- Do not immerse the MVP in liquid.
- The MVP is constructed from durable, chemically resistant materials. However, some chemicals can stain and even soften the front membrane panel if not immediately rinsed.
- If a spill occurs on the MVP's exterior, follow these steps:
 1. Immediately wipe up the spill.
 2. Wash the area with water and soap. Dry the area.
 3. To disinfect the area, wipe down the MVP with a 10% chlorine bleach and distilled water solution, SANI-CLOTH™ wipes (Hamilton P/N 60545), or RBS-VIRO® (a de-proteinizing detergent, Hamilton P/N 18309).
 4. Dry the area.

Avoid caustic or acid cleaning solutions. Using a bleach solution to wipe down the front of the MVP is acceptable; avoid wiping down the rear of the MVP with a bleach solution. Bleach will damage electrical connectors.

If valve and tubing are contaminated or if they come in contact with biohazard samples, thoroughly purge and disinfect valve and tubing with a cleaning solvent that is compatible with the fluids previously run through the system. To flush out contaminants, follow safe laboratory practices in selecting and using a cleaning fluid. Depending on the sample run, you may want to use deionized water, urea, ethanol, or a bleach and water solution for cleaning.

5.2 Periodic Maintenance

Frequency of cleaning depends upon the liquids you typically use and upon your use of the MVP. If you use the MVP daily, purge the tubing and valve at the close of each experiment and each work shift with deionized water (or other compatible solution). Leave tubing and valve filled with liquid, with tube ends in beakers of deionized water.

➔ **Note: Leaving buffers or salt solutions in the valve and tubing could result in crystallization and blockage of tubing and permanent damage to the valve ➔**

At the conclusion of each work shift, disinfect the MVP by pumping ethanol or a 10% bleach solution through the valve and tubing.

If fluid paths contain aqueous solutions, flush the system by replacing the system fluid container with a deionized water container and pumping several times the system volume through each of the valve ports. Do not forget ports that are used infrequently.

If fluid paths contain non-aqueous solutions, flush the system with an intermediate solvent. Then use deionized water as the system storage fluid. The system's cleaning fluid may remain in the tubing overnight.

For long term storage, purge all tubing and all ports of the valve. Cycle air through all tubing and port until the system is dry. Cover the MVP to protect it from damage.

5.3 Troubleshooting

The following table describes some commonly encountered problems, their probable causes, and corrective procedures. There are no user-serviceable parts except for valves and tubing.

Table 5-1. MVP Troubleshooting Chart

Problem	Possible cause	Corrective procedure
Instrument does not power up	disconnected power supply or faulty power outlet	Connect power supply to outlet, and check power source from outlet.
MVP operates normally, but power LED is not lit	faulty LED	Call Hamilton Company Service Department. (phone # 800-527-5269)
LED is flashing	invalid command	Check communications format.
	valve overload or error	Reinitialize the instrument. If the problem persists call Hamilton Company's Service Department.

continued

Table 5-1, continued



Problem	Possible cause	Corrective procedure
valve does not rotate	disengaged valve drive	Reseat valve and reinitialize instrument.
	faulty valve	Replace valve.
		Check for proper indexing pin setting
		Remove valve from the MVP and initialize. If the driver mechanism does not rotate during initialization, call Hamilton Company Service Department.
		Wearing protective eye wear, remove tubing from the ports of the valve and initialize. Look into any valve port to see if it opens and closes during operation. If it does not open and close, replace the valve.
valve rotates, but no fluid moves through the valve	faulty or blocked tubing	Check tubing for blockages, crimps, or loose fittings; replace tubing.
	unmatched valve and switch block settings	Check switch block settings, and ensure they match the installed valve table.
	communications problems	Disconnect cables and operate the MVP using front panel membrane keys; check and reset system configurations; replace valve and tubing. If all else fails, contact Hamilton Company Service Department.



Section 6. Ordering Valves, Accessories, and Replacement Parts

This section provides information on valve configuration and flow patterns, and provides part numbers for valves, accessories, and replacement parts for the serial MVP.

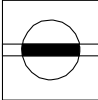
6.1 Valve Configurations and Part Numbers

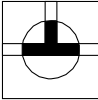
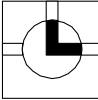
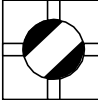
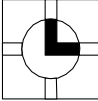
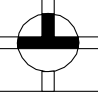
Table 6-1. Valve Configurations and Part Numbers for MVP Valves

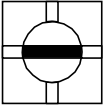
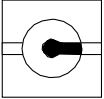
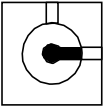
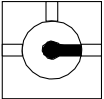
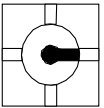
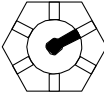
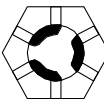
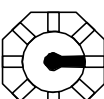
Flow Diagram	Flow Description	Valve Description	HVM Part No.	HVXM Part No.
	180° Flow	1-1	36650	36723
	90° Right Angle	2-2	36651	36724
	"T" 3-port	3-3	36652	36799
	90° Right Angle	3-2	36653	36756
	4-port	4-4	36654	36757
	90° Right Angle	4-2	36717	36780
	"T" 3-port	4-3	36718	36779

Flow Diagram	Flow Description	Valve Description	HVM Part No.	HVXM Part No.
	180° Flow	4-1	36655	36796
	2-way Distribution	1-5	36657	36714
	2-way Distribution	2-5	36658	36722
	3-way Distribution	3-5	36659	36758
	4-way Distribution	4-5	36719	36759
	6-way Distribution	6-5	N/A	36760
	6-way Loop	6-6	N/A	36781
	8-way Distribution	8-5	N/A	36766
	8-way Loop	8-7	N/A	36782

6.2 Accessories and Replacement Parts

Table 6-2. Accessories and Replacement Parts for the Serial MVP

Item Description	DIN Protocol Part Number	Protocol 1 Part Number
Serial MVP (RS-232) without Valve	36790	36798
*Communication Cable for Serial MVP DB9 to DB9, M/F, MVP to computer	36786	77908
*Communication Cable for Serial MVP DB9 to DB25, M/F, MVP to computer	N/A	77909
*Communication Cable for Serial MVP DB9, M/M, MVP to MVP in Daisy Chain	36818	77902
Jumper or Shunt for Converting from DIN to Protocol 1	6539086	6539086
Serial MVP Operator's Manual	69096	69096
**Power Adapter, 120VAC/24VDC, 500 mA	6500025	6500025
**Power Adapter, 220VAC/24VDC, 500 mA	6500026	6500026
**Power Cord for P/N 6500026	6541005	6541005
**Universal Power Supply, 24VDC, 800 mA	6500028	6500028
MVP Valve Porting Label Set	36778	36778
*Refer to Figure 6-1 for cable wiring specifications.		
**Refer to Figure 6-2 for power adapters and cable specifications.		

Figure 6-1. Communication Cable Configurations

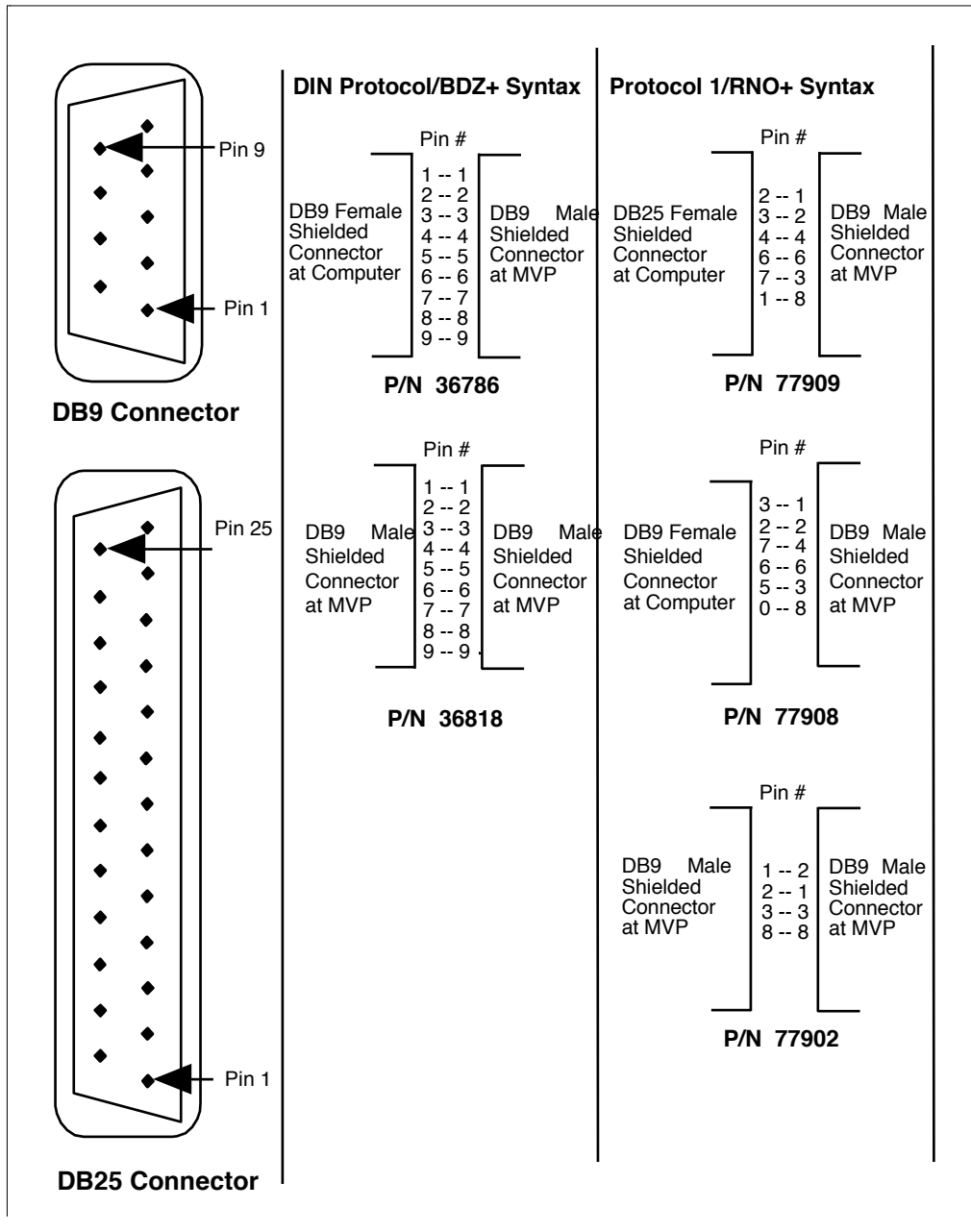
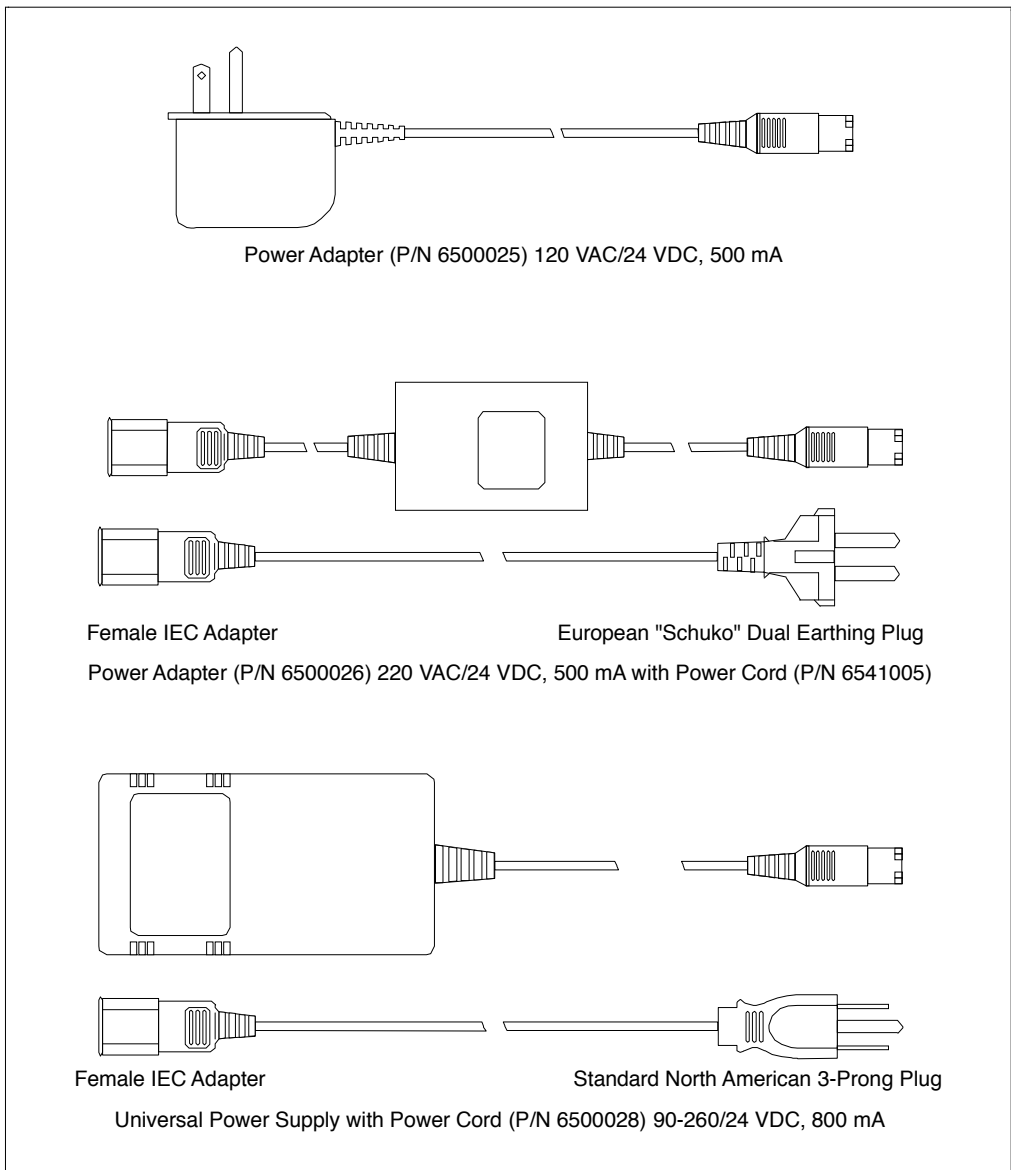

Figure 6-2. Power Adapters and Power Cable Configurations



Glossary

baud

A measurement of the speed at which information can be transmitted between computer devices. If the baud rate is 9600, 9600 bits can be transmitted per second.

boot

To bring the operating system into computer memory to begin programming or running a program.

command

A sequence of letters, numbers, or other characters that represent an instruction a computer transmits to an instrument during programming.

command string

A combination of computer commands.

cursor

A position indicator on a computer monitor that shows where to enter data or change a character.

daisy chain

A string of instruments connected in a serial configuration.

default

A predetermined value in a program or in computer circuitry that an operator may or may not alter.

download

To transfer information from one computer to another.

enter key

The “return” key on a computer keyboard is also referred to as the <Enter> key.

execute

To run a computer program or a method; to interpret machine instructions to perform programmed operations.

format

A predetermined value in a program or in computer circuitry that an operator may or may not alter.

hardware echoed

Transmission of information from one piece of equipment to another via circuitry.

initialize

To establish the basic conditions for starting a process. An instrument initializes before the PRIME function is activated or before a programmed procedure is run.

interface

A connection for linking major components to a computer. The SERIAL interface connects a liquid handling station to a computer. The PARALLEL interface connects a printer to a computer.

LED

Light Emitting Diode used in electronic displays.

power-down

To turn off an electrical device.

power-up

To turn on an electrical device.

prime

To make an instrument ready for operation. Fluid running through the tubing lines of an instrument ensure that neither bubbles nor air gaps exist in the tubing. You must prime the system before using it for the first time, at the start of a work day, and between fluid changes.

program

A coded set of instructions that a computer executes.

Index

A, B, C

auto-addressing
.....3-10,3-11, 3-12, 3-15, 3-21, 4-3
broadcast-addressing3-21
command format errors3-24
correcting errors3-24

D, E, F, G

DIP Switch S1
..... 2-9, 3-3, 3-5, 3-6, 3-7, 3-23, 3-24
DIP Switch S2
.... 2-9, 3-4, 3-5, 3-7, 3-10, 3-11, 3-19, 3-23
distribution valve 2-12, 6-3
errors2-4, 3-1, 3-19, 3-21, 3-24, 4-5

H, I, J, K

HVM valve..... 1-1, 2-6, 2-10, 2-12, 6-2, 6-3
HVXM valve1-1, 2-6, 2-10, 2-12, 6-2, 6-3
initialization..... 2-7, 3-3, 3-4, 3-7, 3-22,
..... 3-23, 3-24, 4-2, 4-3, 4-5, 5-4, 5-5
input/output ports1-2, 2-7, 2-9, 3-4

L, M, N, O

LED/error indicator 2-4, 2-5, 3-24, 5-4
loop valve2-12, 6-3

P, Q, R

position errors3-24
power adapter
.....1-3, 2-8, 2-9, 3-4, 3-23, 6-4, 6-6
Returned Goods Authorization Number . 1-4

S, T, U, V, W, X, Y, Z

test mode 2-9, 3-6, 3-7, 3-24
tubing
.....2-10, 2-11, 3-3, 3-23, 3-25, 5-2, 5-3, 5-4, 5-5
universal power supply 2-9, 6-4, 6-6
valve connector port2-5, 2-6, 2-10
valve indexing pin 2-5, 2-6, 2-10
valve position indicator 2-5, 2-6



HAMILTON
THE MEASURE OF EXCELLENCE™

Hamilton Company

4970 Energy Way
Reno, Nevada 89502 USA
Toll-Free: 800-648-5950
Telephone: +1-775-858-3000
Fax: +1-775-856-7259
e-mail: sales@hamiltoncompany.com

Hamilton Bonaduz AG

Via Crusch 8
CH-7402
Bonaduz/Switzerland
Telephone: +41-(0)81-660-60-60
Fax: +41-(0)81-660-60-70
e-mail: marketing@hamilton.ch

Hamilton Deutschland GmbH

Daimlerweg 5A
64293 Darmstadt/Germany
Telephone: +49-(0)6151-66706-0
Fax: +49-(0)6151-66706-66
e-mail: sales@hamiltongmbh.de

Hamilton Northern Europe

Unit 2, Enterprise Way
Aston Science Park
Birmingham, B7 4BH, U.K.
Telephone: +44-(0)121 2600301
Fax: +44-(0)121 2600302
e-mail: sales@hamiltongb.co.uk

Hamilton France S.A.R.L.

Parc de Moulin de Massy
37 rue du Saule Trapu
91300 MASSY
France
Telephone: +33-(0)1-69-75-16-16
Fax: +33-(0)1-60-11-57-16
e-mail: Hamilton.France@wanadoo.fr

Quality Hamilton Products:

MICROLITER™ Syringes
GASTIGHT® Syringes
Chromatography Syringes
Syringes for Life Science
Instrument Syringes
SoftGrip™ Pipettes
Miniature Valves
Modular Valve Positioner
Laboratory Fittings, Adapters & Tubing
Precision Syringe Pumps
MICROLAB® Diluters & Dispensers
Electrochemical Sensors
DURACAL™ Buffer Solutions
HPLC Columns & Resins

Laboratory Automation for:

Drug Discovery
Genomics
Proteomics
Forensic
In Vitro Diagnostics

<http://www.hamiltoncompany.com>
Sales/Support USA 1-888-525-2123